

The EMRCM is a solution to architectural obstructions (like a T-grid ceiling on a 45° axis from the screen) where the projector can be stored in the ceiling but not in the proper projection orientation.

Additionally, the EMRCM is a useful tool for rotating a projector to a second screen position in multi-purpose rooms.

- 355° maximum rotation for multiple viewing positions at varying heights
- Two preset positions
- For use with third-party RS232 control systems (AMX/Crestron/Extron)
- Quiet, smooth operation

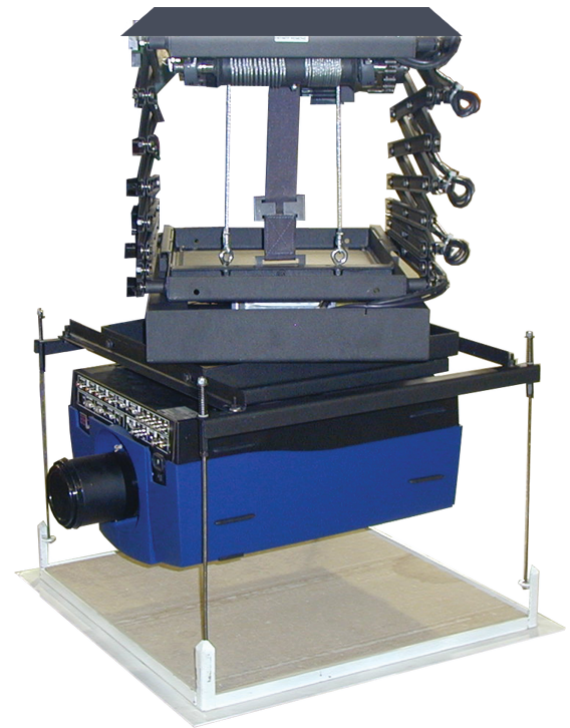

EMRCM 14.5" w x 17.8" d x 5.0" h 20 lbs.

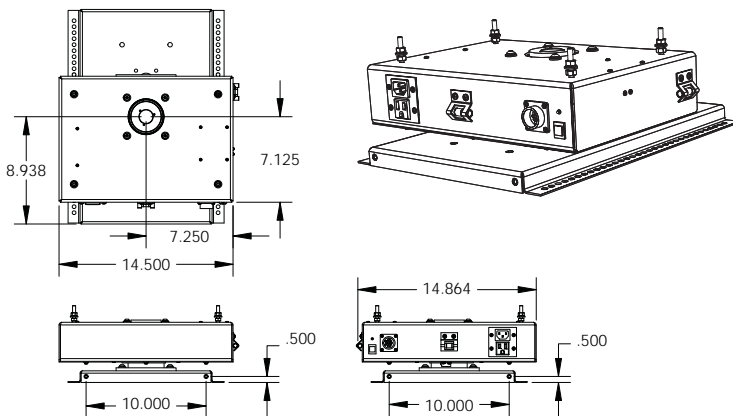

Dimensions do not include lift, projector and closure system.  
Contact Sales for dimensional drawings.

Metric conversion: inches x 25.4

- Weight capacity: 100 lbs. (including closure panel) - Unit weight: 20 lbs.
- Electronics include power supply, drive motor, and hand held lift controller
- Integrated cable management
- PC utility software included for programming rotational and vertical positions
- Controlled via RS232 using third party system
- Power requirements: 110V, 1 amp; 220V, .5 amp
- Cannot be used with other manufacturers lifts
- Requires Display Devices lift and mount system
- Specify projector make/model
- May not be used on the IBL Lift Series
- 1 year warranty

List Price \$2,785