

DRAWING REVISION BLOCK						
REV	ECO	DESCRIPTION	DRAWN	CHECKED	APPROVED	DATE
A		RELEASED FOR PROTOTYPE	JTW			8/6/2010

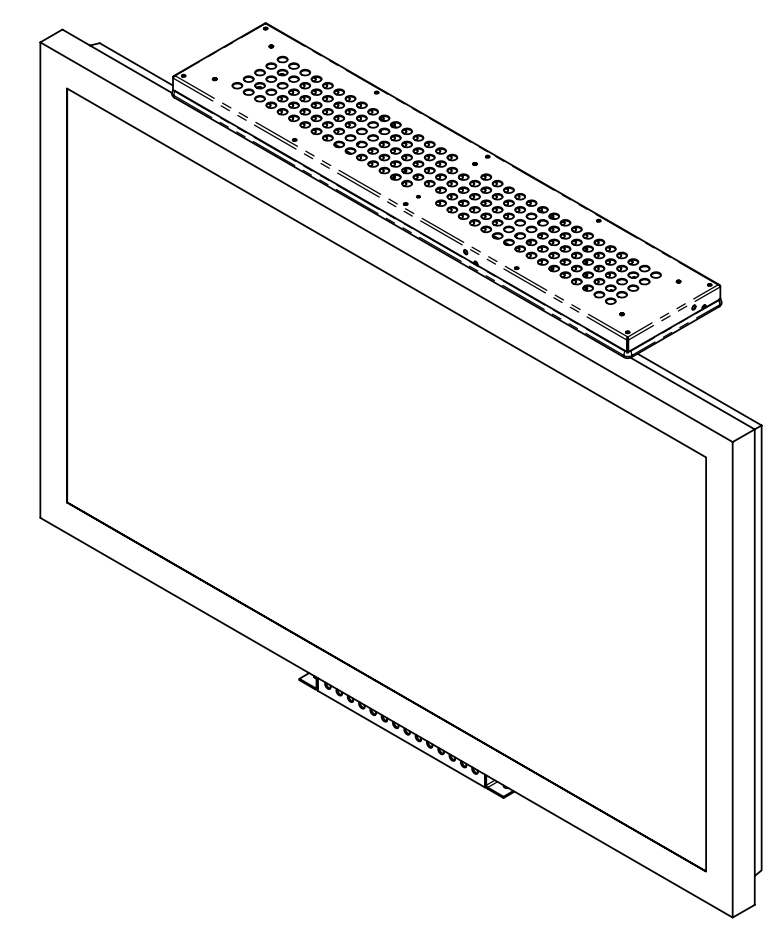
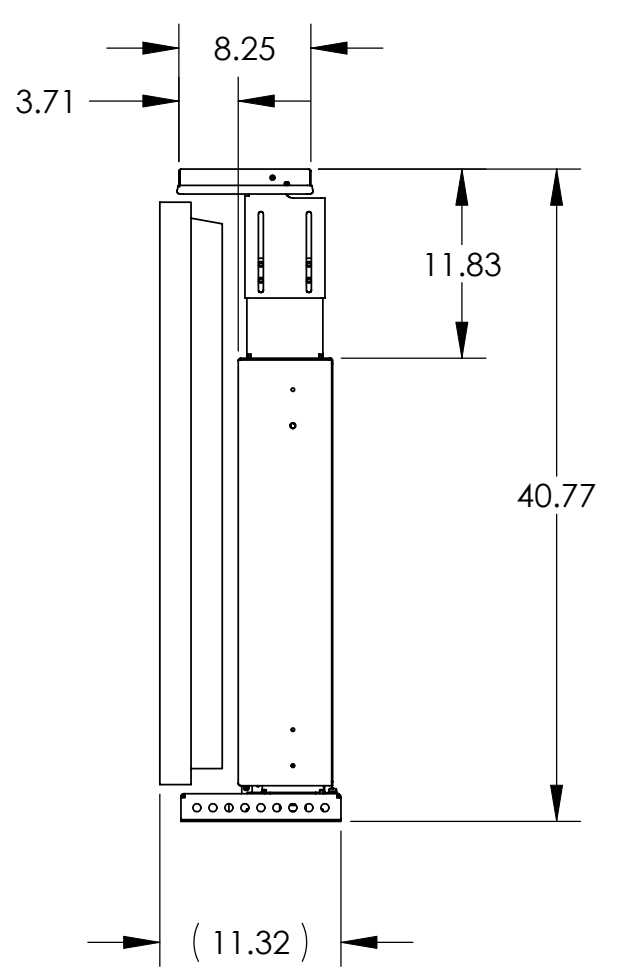
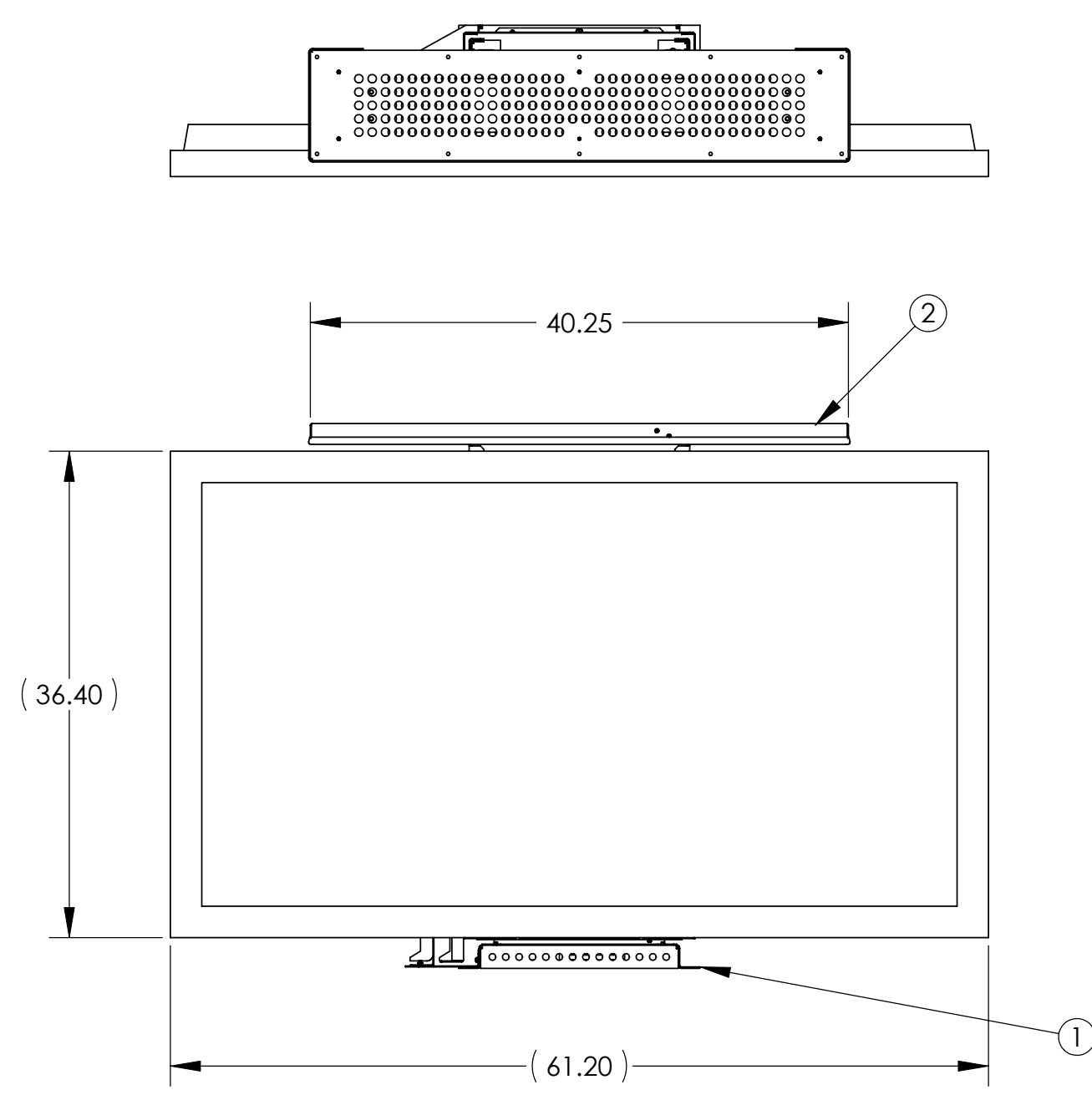

ITEM NO	QTY	PART NO	DESCRIPTION
1	1	99-200	COLUMN LIFT
2	1	99-298	SAFETY LID ASY 60"

6. SHOWN WITH 65" LCD. LCD MOUNT TBD. STANDARD OPT20 FRAME DDI # 111-516 NOT SHOWN.
5. ALL THREADS TO BE FREE OF POWDER COAT AND, OR PAINT.
4. DEBUR ALL SHARP EDGES.
3. ☒ = ITEM CHANGED AT LAST REVISION.
2. ALL DIMENSIONS ARE IN INCHES.
1. DO NOT SCALE DRAWING.
- NOTES: UNLESS OTHERWISE SPECIFIED

THE INFORMATION CONTAINED IN THIS DRAWING IS THE PROPERTY OF DISPLAY DEVICES, INC. ANY REPRODUCTION IN PART OR WHOLE WITHOUT THE WRITTEN PERMISSION OF DISPLAY DEVICES, INC IS PROHIBITED		UNLESS OTHERWISE SPECIFIED DIMENSIONS ARE IN INCHES. TOLERANCES: .XX = ± .02 .XXX = ± .010 .XXXX = ± .0050 ANGLE = ± 0.5		DISPLAY DEVICES 5880 SHERIDAN BLVD ARVADA, CO 80003	
DRAWN JTW		DATE 8/6/2010		TITLE PL6000 FLAT PANEL LIFT 60" LCD	
CHECKED		DATE		SIZE B	DRAWING NO. 99-303
MATERIAL SEE BOM		SCALE NONE		FILE NAME 99-303.SLDDRW	REV A
FINISH -				SHEET 1 OF 1	