

DRAWING REVISION BLOCK						
REV	ECO	DESCRIPTION	DRAWN	CHECKED	APPROVED	DATE
A	-	RELEASE FOR PRODUCTION	RLS			12/31/2003
B	-	REMOVED HARDWARE LIST	RLS			4/5/2004
C	ECO-0470	ADDED MOUNTING HARDWARE TO BOM	BRM			11/20/2006

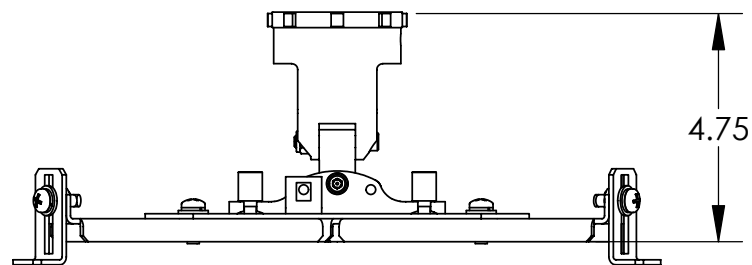
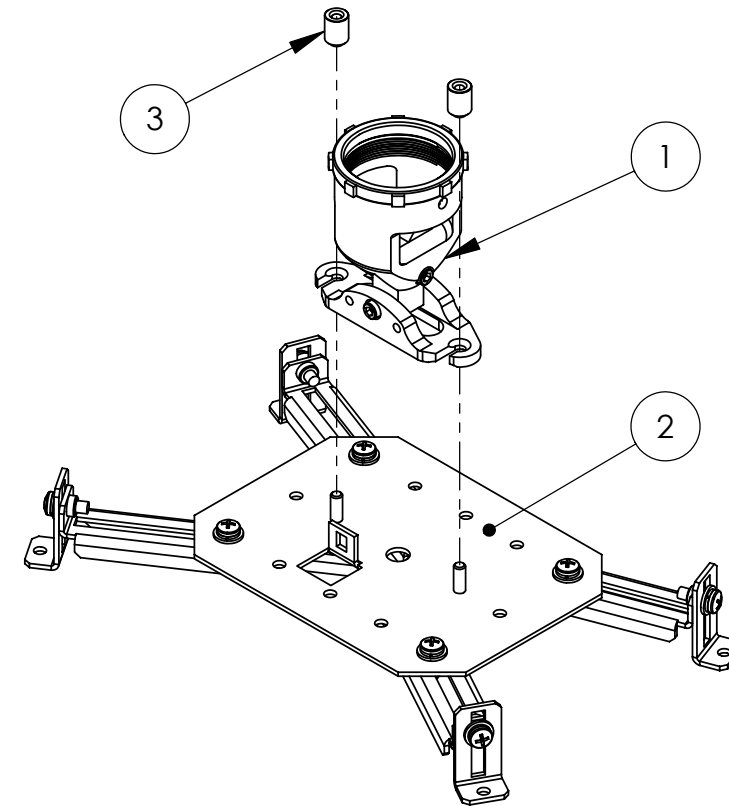
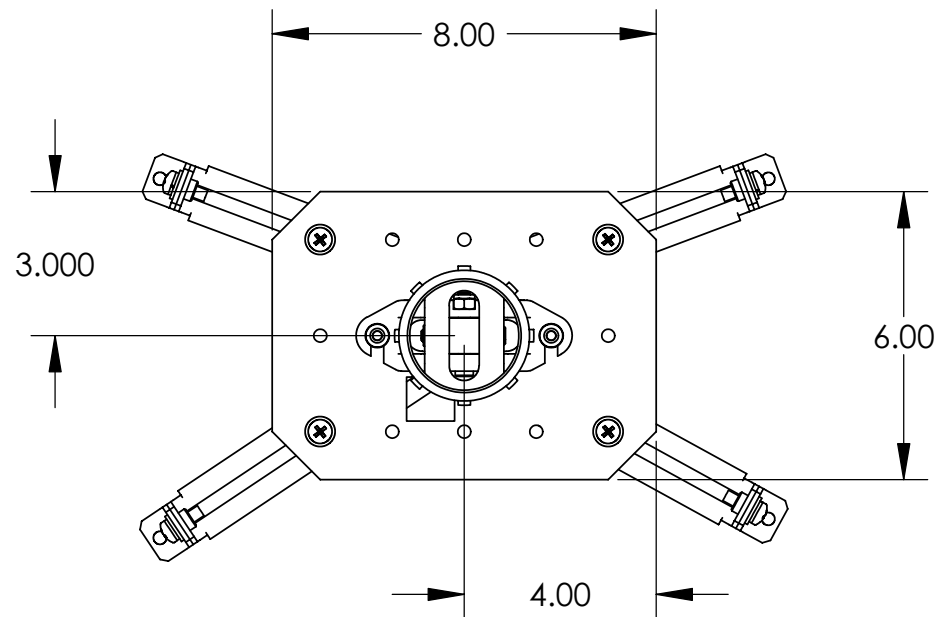

ITEM NO	QTY	PART NO	DESCRIPTION	ITEM NO	QTY	PART NO	DESCRIPTION
1	1	72-600	KNUCKLE MOUNT ASM, 2" BLACK	9	4	5900-25150	M4 X 0.8 X 12, PH, P 8.8, ZI
2	1	72-195	FLEX MOUNT	10	4	5950-10550	M5, FL WASHER, STL, ZI
3	2	72-255SD	THUMB NUT FOR STAT MNTS	11	4	5950-11050	M5 LK WASHER, STL, ZI
4	4	5950-10450	M3, FL WASHER, STL, ZI	12	4	5900-21300	M5 X 0.8 X 12, PH, P, STL, ZI
5	4	5950-10900	M3, LK WASHER, STL, ZI	13	4	5950-14500	M6, FL WASHER, STL, ZI
6	4	5900-41890	M3 X 12 PH,P,STL,ZI,8.8	14	4	5950-11100	M6, LK WASHER, STL, ZI
7	4	5950-10500	M4, FL WASHER, STL, ZI	15	4	5900-41230	M6X1.0 X 12, PH, P, STL, ZI
8	4	5950-10950	M4, LK WASHER, STL, ZI				

6. ITEMS 4-15 ARE NOT SHOWN IN DRAWING, BUT NEED TO BE INCLUDED IN PACKAGE.
5. ALL THREADS TO BE FREE OF POWDER COAT AND, OR PAINT.
4. DEBUR ALL SHARP EDGES.
3. X = ITEM CHANGED AT LAST REVISION.
2. ALL DIMENSIONS ARE IN INCHES.
1. DO NOT SCALE DRAWING.

NOTES: UNLESS OTHERWISE SPECIFIED

THE INFORMATION CONTAINED IN THIS DRAWING IS THE PROPERTY OF DISPLAY DEVICES, INC. ANY REPRODUCTION IN PART OR WHOLE WITHOUT THE WRITTEN PERMISSION OF DISPLAY DEVICES, INC IS PROHIBITED		UNLESS OTHERWISE SPECIFIED DIMENSIONS ARE IN INCHES. TOLERANCES: .XX = ± .02 .XXX = ± .010 .XXXX = ± .0050 ANGLE = ± 0.5		DISPLAY DEVICES 5880 SHERIDAN BLVD ARVADA, CO 80003	
				TITLE FLEX MNT W 2" KNUCKLE	
DRAWN	RLS	DATE	12/30/2003	SIZE	DRAWING NO.
CHECKED		DATE		B	72-725
MATERIAL	-				
FINISH	-			SCALE	FILE NAME
				NONE	72-725.SLDDRW
				SHEET 1 OF 1	