

DRAWING REVISION BLOCK						
REV	ECO	DESCRIPTION	DRAWN	CHECKED	APPROVED	DATE
AX1	-	RELEASE FOR PROTOTYPE	CDO			2/4/2008
AX2	-	ADD O-RING AND COVER PLATE	CDO			2/21/2008
AX3	-	ADD STOPS FOR PAN AND TILT	CDO			5/28/2008

ITEM NO	QTY	PART NO	DESCRIPTION
1	1	100-022	12" POLE ASSEM - PT300
2	1	140-074	COMPLETE DRIVE UNIT ASSEM
3	1	140-085	TILT ADAPTER RING LEFT
4	1	140-076	BOTTOM ADPTR TO 12IN POLE
5	1		O-RING - 2.125 OD
6	4	5950-10250	3/8" FLAT WASHER-STAINLESS STEEL
7	4	5950-10750	3/8" LOCK WASHER-STAINLESS STEEL
8	4	5900-39100	3/8-16 X 3/4" BHCS-STAINLESS TEEL
9	4	5900-19450	1/4-20 X 3/4 SHCS-STAINLESS STEEL
10	1	5800-12550	O-RING - 2.5 OD
11	2		FLEX TUBE CONNECTOR
12	1		FLEX TUBING - 33.50" LONG
13	1	100-105	CAMERA MNT - PT300
14	2	140-079	STOP, PAN
15	8	5900-00174	10-32 X 3/8", SS CUP, HX, SS
16	2	140-086	TRIP COLLAR
17	2	140-087	STOP
18	1	140-081	STOP, TILT
19	4		O-RING
20	6	5900-31600	10-32 X 3/4", SHCS, HX, SS
21	1	140-084	TILT ADPATER RING-PT-300
22	4	5900-38800	1/4-20 X 1-1/2", FHCS, HX, SS
23	4	5950-00013	#4, LOCK WASHER, SS
24	4	5900-18850	4-40 X 1/2, SHCS, HX, GR8, BO
25	2	5950-00018	#10, LK WASHER, STL, BZ
26	6	5900-32950	8-32 X 1/4, SS CUP, HX, STL, BO

THE INFORMATION CONTAINED IN THIS DRAWING IS THE PROPERTY OF DISPLAY DEVICES, INC. ANY REPRODUCTION IN PART OR WHOLE WITHOUT THE WRITTEN PERMISSION OF DISPLAY DEVICES, INC IS PROHIBITED		UNLESS OTHERWISE SPECIFIED DIMENSIONS ARE IN INCHES.  TOLERANCES: .XX = ± .02 .XXX = ± .010 .XXXX = ± .0050 ANGLE = ± 0.5		<b>DISPLAY DEVICES</b> <b>5880 SHERIDAN BLVD</b> <b>ARVADA, CO 80003</b>	
DRAWN		DATE		TITLE	
CDO		2/4/2008		PT350 CMPLT ASSEM	
CHECKED		DATE		DRAWING NO.	
				140-071	
MATERIAL		SCALE		REV	
NONE		NONE		AX3	
FINISH		FILE NAME		SHEET 1 OF 2	
NONE		140-071.SLDDRW			

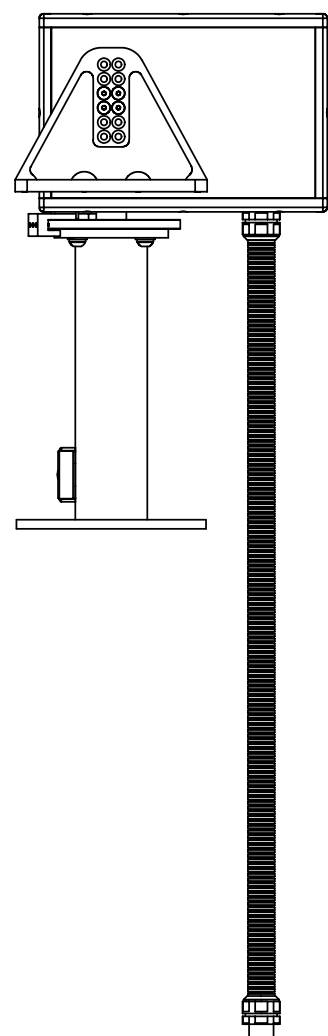
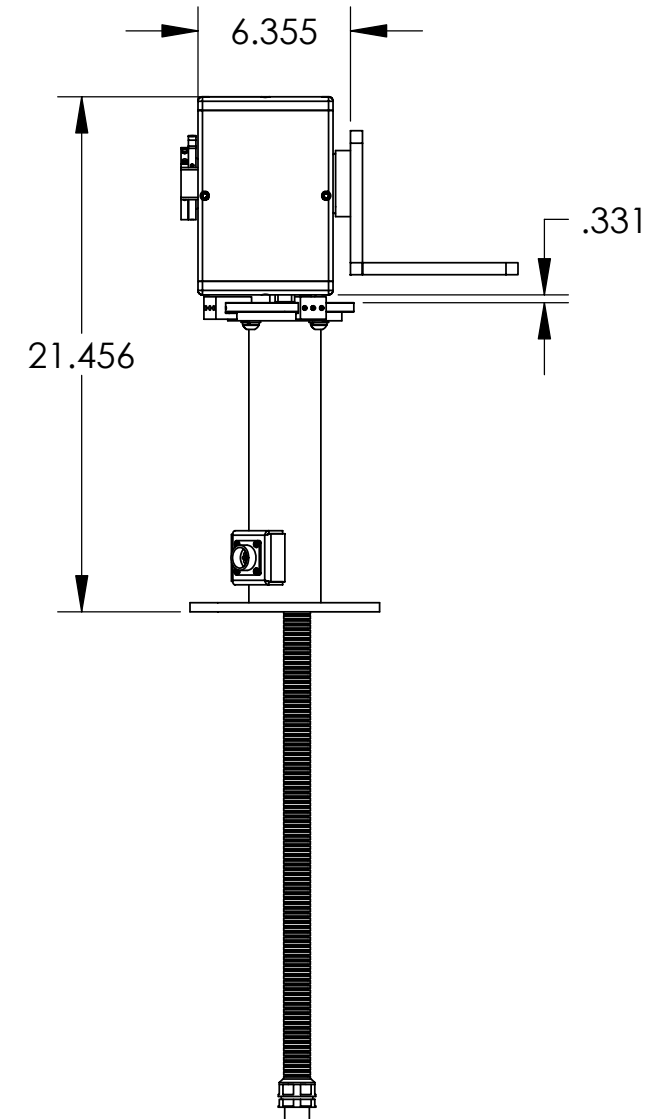
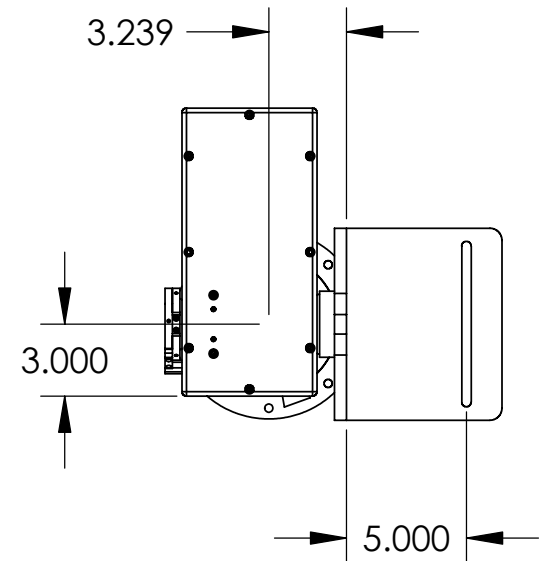

THE INFORMATION CONTAINED IN THIS DRAWING IS THE PROPERTY OF DISPLAY DEVICES, INC. ANY REPRODUCTION IN PART OR WHOLE WITHOUT THE WRITTEN PERMISSION OF DISPLAY DEVICES, INC IS PROHIBITED		UNLESS OTHERWISE SPECIFIED DIMENSIONS ARE IN INCHES. TOLERANCES: .XX = ± .02 .XXX = ± .010 .XXXX = ± .0050 ANGLE = ± 0.5		<b>DISPLAY DEVICES</b> 5880 SHERIDAN BLVD ARVADA, CO 80003	
DRAWN		DATE		TITLE	
CDO		2/4/2008		PT350 CMPLT ASSEM	
CHECKED		DATE		SIZE	DRAWING NO.
				B	140-071
MATERIAL		NONE		SCALE	FILE NAME
FINISH		NONE		NONE	140-071.SLDDRW
				REV	SHEET 2 OF 2
				AX3	