

DRAWING REVISION BLOCK						
REV	ER	DESCRIPTION	DRAWN	CHECKED	APPROVED	DATE
B	0253	ADDED HOLE FOR POWDER COATING ON ITEM 2	JTW			12/17/2004

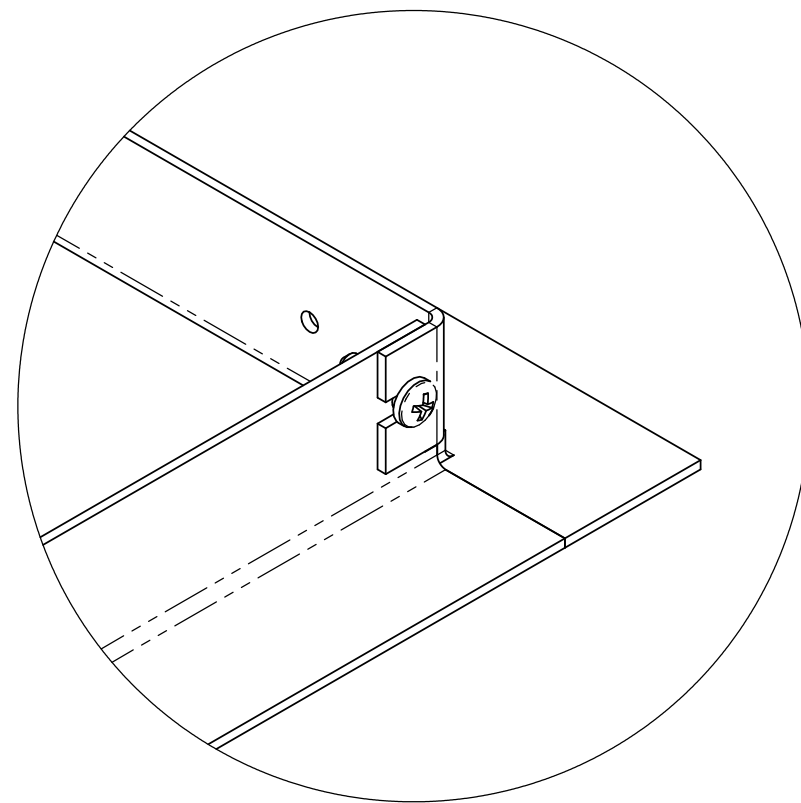
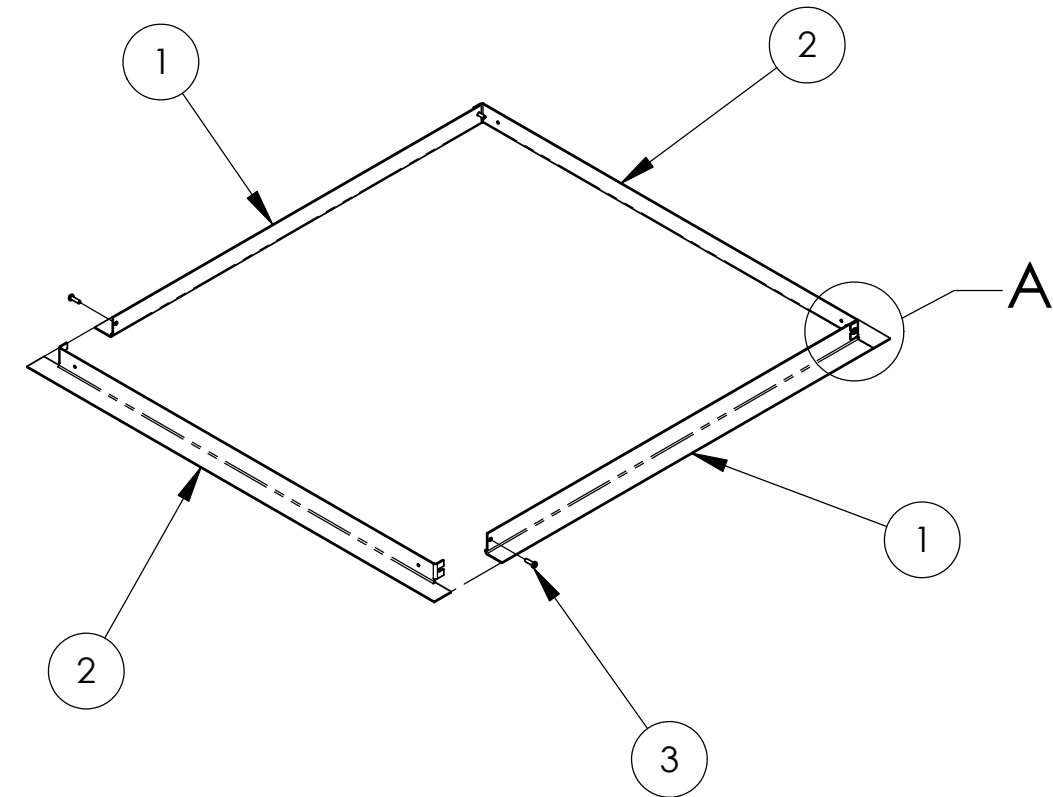
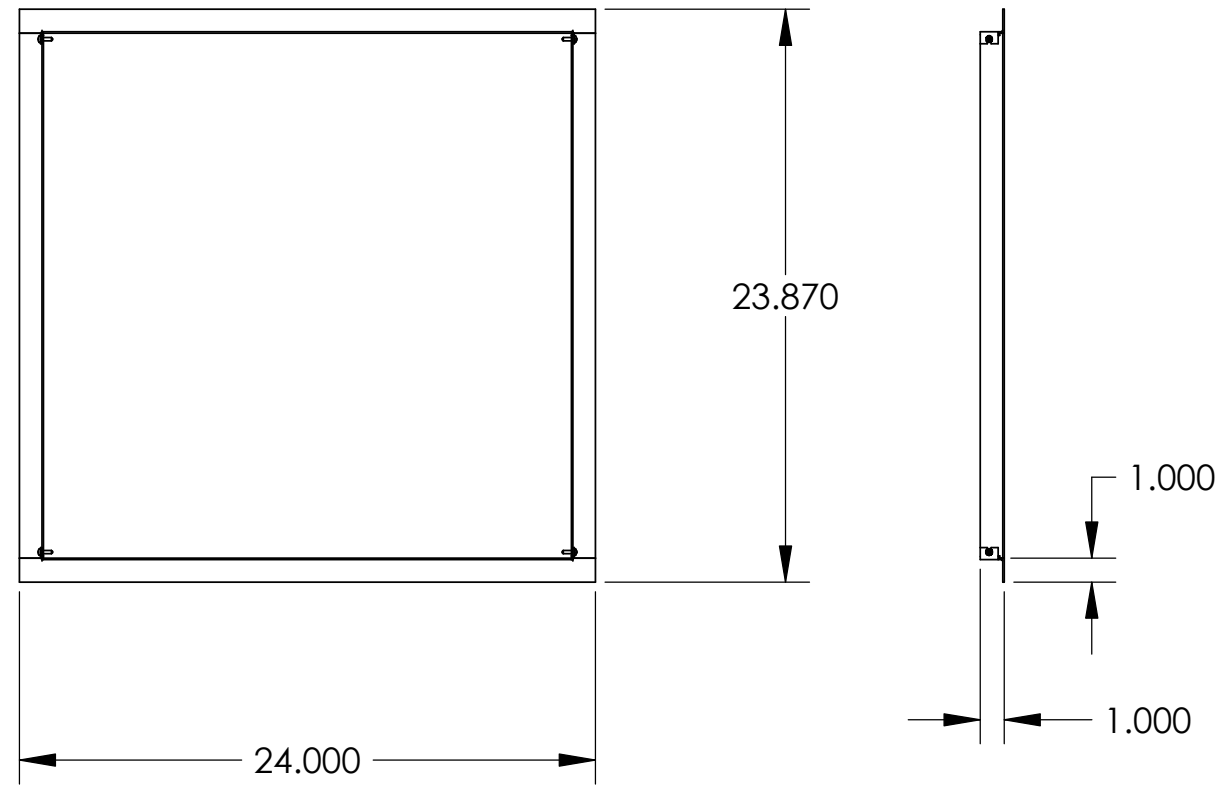

DETAIL A
SCALE 1:1

ITEM NO	QTY	PART NO	DESCRIPTION
1	2	120-356	TRIM EDGING SIDE
2	2	120-357	TRIM EDGING - END
3	4	5900-2110	#6 X 1/2, SELF TAPPER, PH, P, STL, ZI

		DISPLAY DEVICES, INC 5880 SHERIDAN BLVD ARVADA, CO 80003				
		TITLE 2X2 TRIM RING				
THE INFORMATION CONTAINED IN THIS DRAWING IS THE PROPERTY OF DISPLAY DEVICES, INC. ANY REPRODUCTION IN PART OR WHOLE WITHOUT THE WRITTEN PERMISSION OF DISPLAY DEVICES, INC IS PROHIBITED	UNLESS OTHERWISE SPECIFIED DIMENSIONS ARE IN INCHES. TOLERANCES: .XX = ± .02 .XXX = ± .010 .XXXX = ± .0050 ANGLE = ± 0.5	DRAWN JTW	DATE 5/22/2003	SIZE B	DRAWING NO. 120-355	REV B
MATERIAL SEE BOM		FINISH NONE		SCALE NONE	FILE NAME 120-355.SLDDRW	SHEET 1 OF 1