

DRAWING REVISION BLOCK								
REV	ECO	DESCRIPTION			DRAWN	CHECKED	APPROVED	DATE
A	-	RELEASE FOR PRODUCTION			CRH			7/10/2007

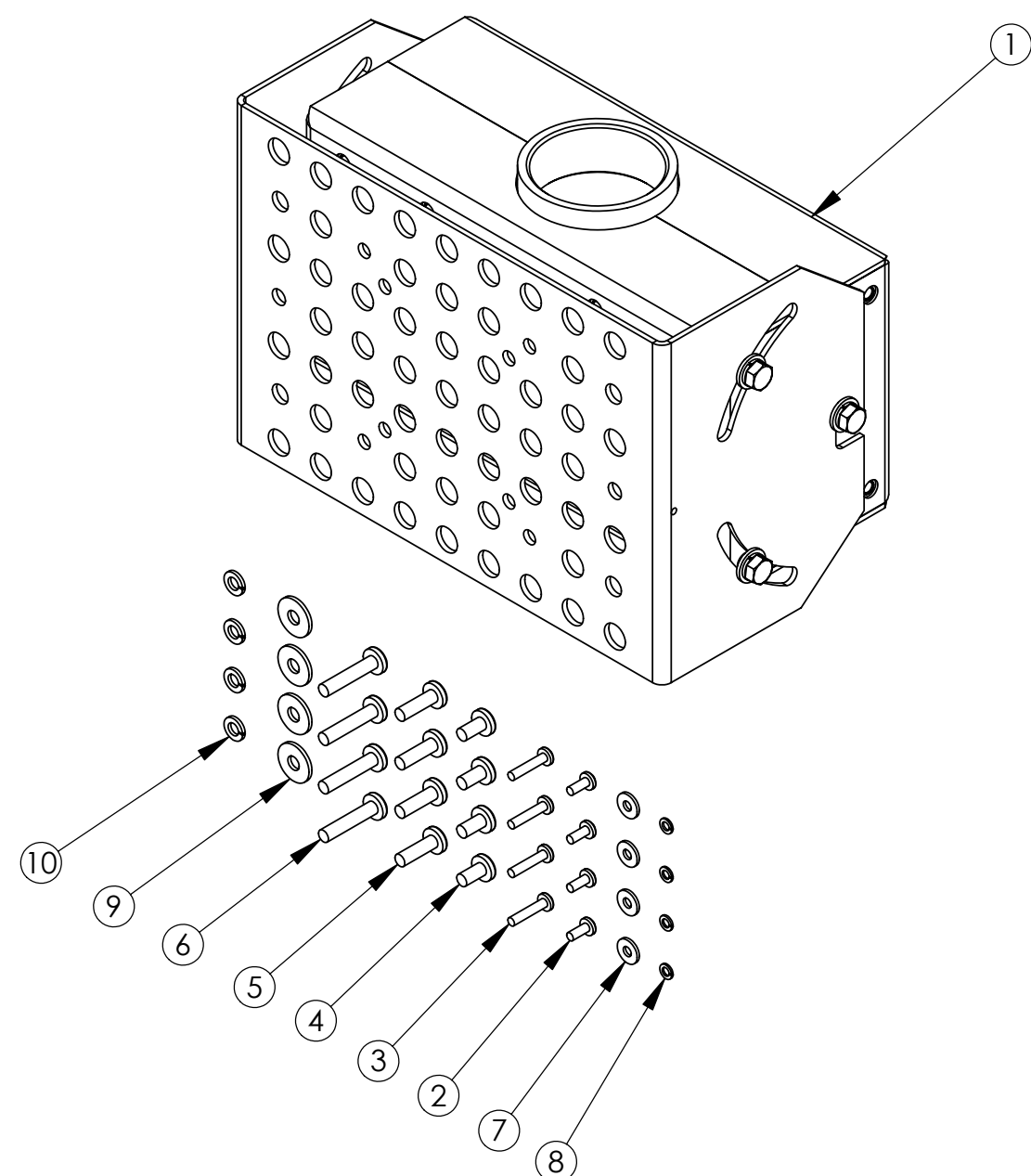

ITEM NO	QTY	PART NO	DESCRIPTION
1	1	65-344	SINGLE PLASMA DISPLAY ASSEMBLY - NARROW
2	4	5900-17650	M4 X 0.7 X 10, PH, P, ZI
3	4	5900-26550	M4 X 0.7 X 20, PH, P, STL, ZI
4	4	5900-41230	M6X1.0 X 12, PH, P, STL, ZI
5	4	5900-27650	M6 X 1.0 X 20, PH, P, STL, ZI
6	4	5900-40920	M6 X 1.0 X 30, PH, P, STL, ZI
7	4	5950-10500	M4, FL WASHER, STL, ZI
8	4	5950-10950	M4, LK WASHER, STL, ZI
9	4	5950-14500	M6, FL WASHER, STL, ZI
10	4	5950-11100	M6, LK WASHER, STL, ZI

- 6. BAG ITEMS 2 - 10 FOR SHIPPING.
- 5. ALL THREADS TO BE FREE OF POWDER COAT AND, OR PAINT.
- 4. DEBUR ALL SHARP EDGES.
- 3. ☒ = ITEM CHANGED AT LAST REVISION.
- 2. ALL DIMENSIONS ARE IN INCHES.
- 1. DO NOT SCALE DRAWING.

NOTES: UNLESS OTHERWISE SPECIFIED

<p>THE INFORMATION CONTAINED IN THIS DRAWING IS THE PROPERTY OF DISPLAY DEVICES, INC. ANY REPRODUCTION IN PART OR WHOLE WITHOUT THE WRITTEN PERMISSION OF DISPLAY DEVICES, INC IS PROHIBITED</p>		<p>UNLESS OTHERWISE SPECIFIED DIMENSIONS ARE IN INCHES.</p> <p>TOLERANCES: .XX = ± .02 .XXX = ± .010 .XXXX = ± .0050 ANGLE = ± 0.5</p>		<p>DISPLAY DEVICES 5880 SHERIDAN BLVD ARVADA, CO 80003</p>	
<p>DRAWN CRH</p>		<p>DATE 7/10/2007</p>		<p>TITLE POLE MOUNT - SINGLE SMALL VESA</p>	
<p>CHECKED</p>		<p>DATE</p>		<p>SIZE B DRAWING NO. 118-044 REV A</p>	
<p>MATERIAL -</p>		<p>SCALE NONE</p>		<p>FILE NAME 118-044.SLDDRW SHEET 1 OF 1</p>	
<p>FINISH -</p>					